

SMPX500 Series of Hybrid Detectors

The SMPX500 series is a range of integrated photodiode amplifiers incorporating a 1.75mm² silicon PIN photodiode, operational amplifier and transimpedance circuitry. The devices provide a voltage output proportional to incident light.

Features

Incorporation of the photodiode and amplifier into a welded metal can minimises noise pickup, leakage current errors and stray capacitance normally associated with discrete designs. Gain and bandwidth options are available to suit a wide range of applications and the devices can be operated from single or dual rail supplies. Lens or Flat window can versions are available to suit the application, as well as optical filters to minimise unwanted signals.

Applications

These devices are especially suited to low-light level or applications where high sensitivity is required:

- Medical instruments
- Document verification
- Laboratory instrumentation
- Position and proximity detectors
- Pollution/environmental monitoring
- Smoke/Gas detectors
- Complements SMPX600 range of Self-Monitoring Emitters

Spectral Response

Custom filters available on request

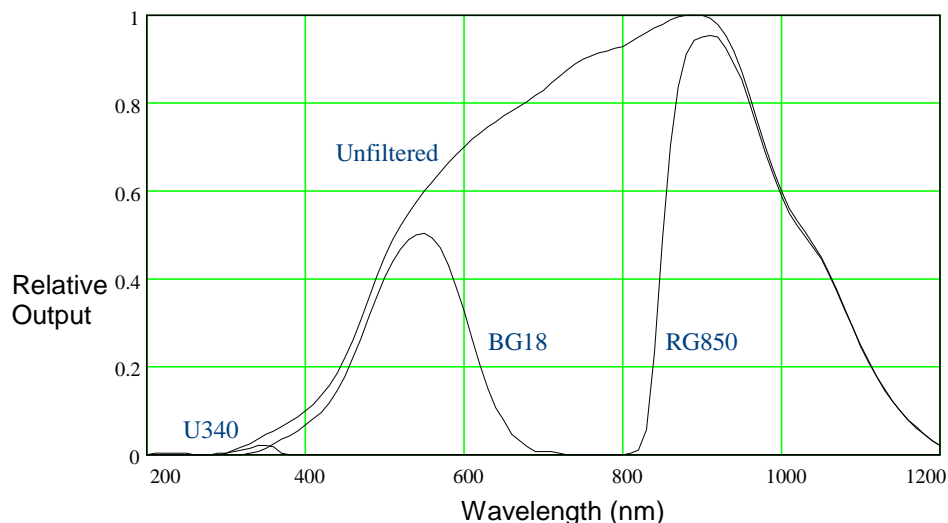

SMPX500 Series of Hybrid Detectors

Typical Characteristics @22°C

Detectors/Application		Units	General Purpose		High Gain		Pulse		High Speed
			SMPX511-WN	SMPX511-LN	SMPX522-WN	SMPX522-LN	SMPX512-WN	SMPX512-LN	SMPX503-LN
DC Supply Voltage (Dual Rail)	V	±2 to ±18	±2 to ±18	±2 to ±18	±2 to ±18	±2 to ±18	±2 to ±18	±2 to ±18	±2 to ±18
DC Supply Voltage (Single Rail)	V	+4 to +36	+4 to +36	+4 to +36	+4 to +36	+4 to +36	+4 to +36	+4 to +36	+4 to +36
Quiescent Current	mA	4	4	4	4	4	4	4	4
Dark Level Noise	Typical mV	2.5	2.5	2.5	2.5	2.5	2.5	2.5	2.5
Amplifier Output Offset	Typical mV	<5	<5	<5	<5	<5	<5	<5	<5
	Maximum mV	10	10	10	10	10	10	10	10
Frequency Response (-3dB)	KHz	10	10	35	35	65	65	90	
Transimpedance Gain	MΩ	10	10	20	20	8.2	8.2	1	
Optical Gain (approx.)	n/a	1	10	1	10	1	10	10	
Detector Output Current	Sink mA	10	10	10	10	10	10	10	10
	Source mA	1	1	1	1	1	1	1	1
Temperature Limits	Operating °C	-20 to +80	-20 to +80	-20 to +80	-20 to +80	-20 to +80	-20 to +80	-20 to +80	-20 to +80
	Storage °C	-30 to +100	-30 to +100	-30 to +100	-30 to +100	-30 to +100	-30 to +100	-30 to +100	-30 to +100
Photodiode Active Area	mm ²	1.75	1.75	1.75	1.75	1.75	1.75	1.75	
Window / Lens	n/a	Window	Lens	Window	Lens	Window	Lens	Lens	

Semelab Plc reserves the right to change test conditions, parameter limits and package dimensions without notice. Information furnished by Semelab is believed to be both accurate and reliable at the time of going to press. However Semelab assumes no responsibility for any errors or omissions discovered in its use. Semelab encourages customers to verify that datasheets are current before placing orders

Document No: 7303
Issue: 5

SMPX500 Series of Hybrid Detectors

Circuit Diagram

All part numbers except SMPX503-LN:

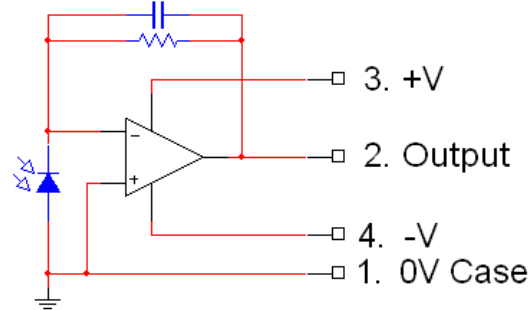

SMPX503-LN:

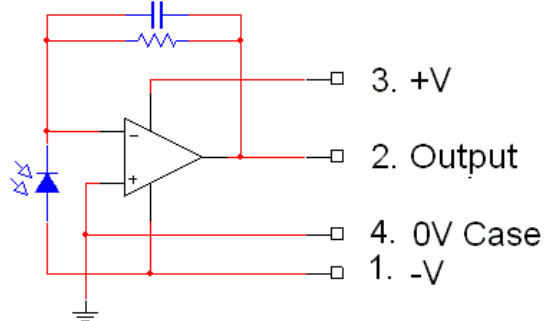

Mechanical

All dimensions in mm.

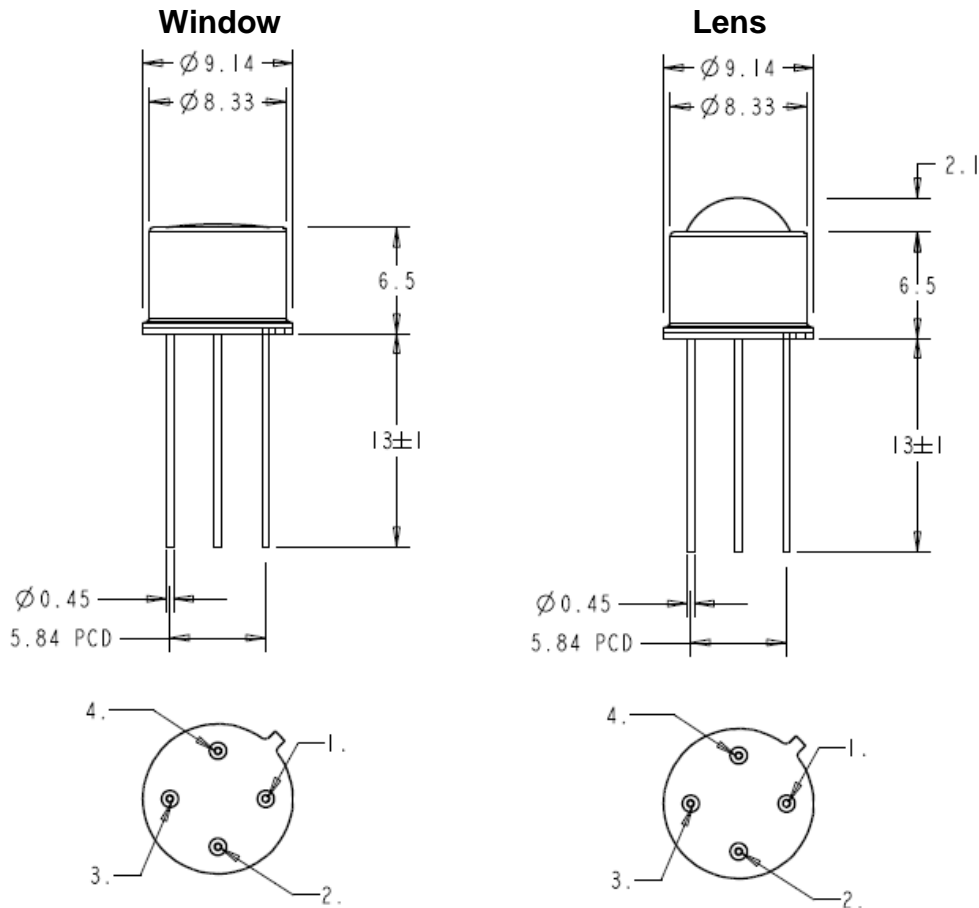

Bottom View